

# 4 STOPCOCKS/VALVES



NORMAG - LABORATORY GLASSWARE



## STOPCOCKS AND STOPCOCKS WITH SIDE ARMS FOR MANIPULATORS

Not only our connecting pieces with spherical ground joint (see chapter 3) but also our stopcocks with arms, made of Borosilicate glass 3.3, distinguish by the high precision of manufacture and the top surface quality. Barrel and hollow glass key of the stopcock are interchangeable. The keeping of the sharp tolerance limits regarding to the angles, mantle line and diameter of the cone leads to a large touching area from barrel and cone. The result is a high vacuum tightness with minimal surface pressure.

Some types of stopcocks are delivered with PTFE or full glass key. Full glass keys are recommended for use at high temperatures.

A retaining device at the key prevents inadvertent removal and gives additional safety for operations under slight overpressure. In this point, the stopcocks fully meet the requirements of DIN 12 540, part 1.

On request, other nominal sizes as described in our standard delivery range are available as well as special designs, e.g. stopcocks in nominal size 3 with bore diameter of 2 or 3 mm.



All stopcocks described below meet the conditions for interchangeability of DIN 12 540, part 1. Due to this fact, the addition "NS" in the catalogue number is not necessary. On the product itself, NS is indicated.

The described quality features are only maintain, when the keys are never turned dry in the barrel. As lubricating substance we recommend the media itself, pastes with PTFE or grease. The substances must be thin applied on the key, and then the key must be turned with slight pressure.

PTFE coated hollow glass keys are available as an alternative for an additional charge. Lubrication is not required for these keys.

## CONNECTING STOPCOCKS

Available in different designs and manufactured according to DIN 12 541 part 1 regarding to the nominal size and dimensions.



Barrels for Teflon keys, please order with addition "polished".

## Single way stopcocks with bending tube arms

Nominal size	Ø bore	d max	Catalogue No. with glass key	Catalogue No. with PTFE key
1	1	10	KSH 02001C 01	KSH 02001CT 01
2	1.5	14.5	KSH 02001C 02	KSH 02001CT 02
3	2.5	14.5	KSH 02001C 03	KSH 02001CT 03
4	4	18.8	KSH 02001C 04	KSH 02001CT 04
6	6	21.5	KSH 02001C 05	KSH 02001CT 05
8	8	24	KSH 02001C 06	KSH 02001CT 06
10	10	29.2	KSH 02001C 07	KSH 02001CT 07
12	12	34.5	KSH 02001C 08	-
15	15	45.0	KSH 02001C 09	-

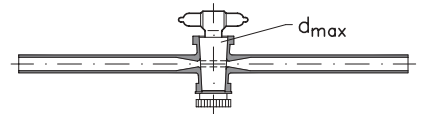

## Single way stopcock with capillary arms

Nominal size	Ø bore	d max	Catalogue No. with glass key
3	2.5	14.5	KSH 02001D 02

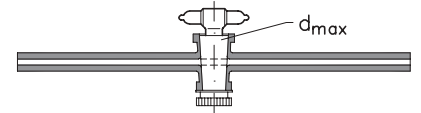

## Single way stopcocks with one enlarged arm

Nominal size	Ø bore	d max	Catalogue No. with glass key	Catalogue No. with PTFE key
2	2	14.5	KSH 02001E 01	KSH 02001ET 01
3	2.5	14.5	KSH 02001E 02	KSH 02001ET 02
4	4	18.8	KSH 02001E 03	KSH 02001ET 03
6	6	21.5	KSH 02001E 04	KSH 02001ET 04
8	8	24	KSH 02001E 05	-
10	10	29.2	KSH 02001E 06	-
12	12	34.5	KSH 02001E 07	-
15	15	45	KSH 02001E 08	-

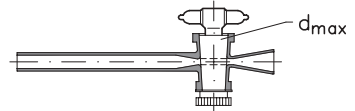

## Single way stopcock for gas sampling tubes

This stopcock has one capillary arm and one enlarged arm.

Nominal size	Ø bore	d max	Catalogue No. with glass key
3	2.5	14.5	KSH 02010E 02

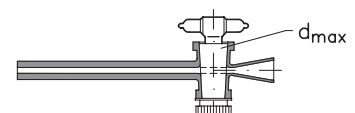

## TWO-WAY STOPCOCKS

According to DIN 12 553, the keys of the stopcocks are fitted with two parallel bores. Delivered with hollow glass plug and either with plain arms or capillary arms.

 Barrels for Teflon keys, please order with addition "polished".

### Two-way stopcocks with bending tube arms

Nominal size	Ø bore	d max	Catalogue No. with glass key	Catalogue No. with PTFE key
2	1.5	14.5	KSH 02004C 01	KSH 02004CT 01
3	2.5	18.8	KSH 02004C 02	KSH 02004CT 02
4	4	21.5	KSH 02004C 03	KSH 02004CT 03
6	6	29.2	KSH 02004C 04	KSH 02004CT 04

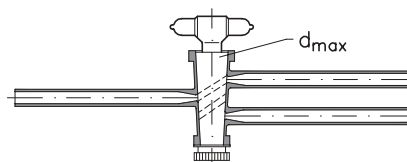

### Two-way stopcocks with capillary arms

Nominal size	Ø bore	d max	Catalogue No. with glass key	Catalogue No. with PTFE key
2	1.5	14.5	KSH 02004D 01	KSH 02004DT 01
3	2.5	18.8	KSH 02004D 02	KSH 02004DT 02

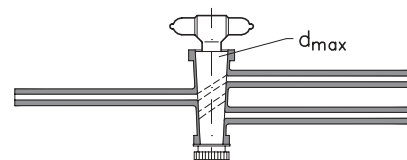

## THREE-WAY STOPCOCKS

Three-way stopcocks are available in different types. Sizes and T-bore in the hollow glass key correspond to DIN 12 554.

### Three-way stopcock with bending tube arms

Nominal size	Ø bore	d max	Catalogue No. with glass key	Catalogue No. with PTFE key
2	1.5	14.5	KSH 02005C 01	KSH 02005CT 01
3	2.5	18.8	KSH 02005C 02	KSH 02005CT 02
4	4	21.5	KSH 02005C 03	KSH 02005CT 03
6	6	29.2	KSH 02005C 04	KSH 02005CT 04
8	8	34.5	KSH 02005C 05	-
10	10	45.0	KSH 02005C 06	-

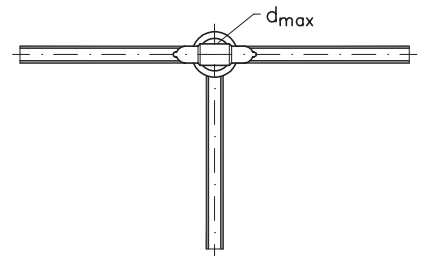

### Three-way stopcock with capillary arms

Nominal size	Ø bore	d max	Catalogue No. with glass key
3	2.5	18.8	KSH 02005D 02

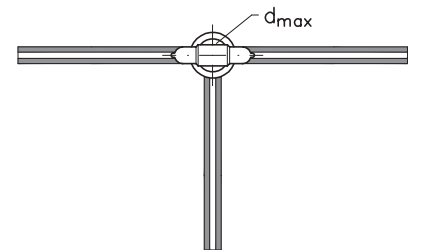

### Three-way stopcocks with enlarged arm

Nominal size	Ø bore	d max	Catalogue No. with glass key
2	1.5	14.5	KSH 02005E 01
3	2.5	18.8	KSH 02005E 02
4	4	21.5	KSH 02005E 03
6	6	29.2	KSH 02005E 04
8	8	34.5	KSH 02005E 05
10	10	45.0	KSH 02005E 06

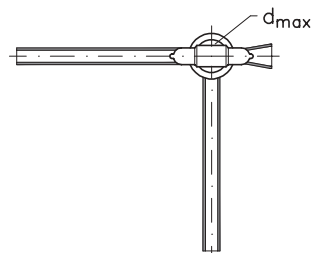

# STOPCOCKS/VALVES

## TAIL STOPCOCKS

These three way conical stopcocks according to DIN 12 555 with axial bottom outlet at the key are used for introduction of nitrogen. Normally, they are delivered with hollow glass key, but with choice of two bending arms or one bending arm and one enlarged arm.

### Tail stopcocks with bending arms

Nominal size	Ø bore	d max	Catalogue No. with glass key
2	1.5	14.5	KSH 02006C 01
3	2.5	18.8	KSH 02006C 02
4	4	21.5	KSH 02006C 03

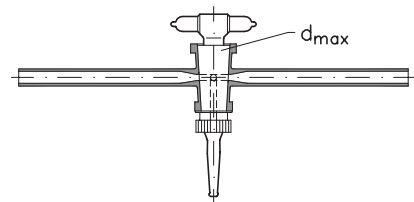

### Tail stopcocks with enlarged arm

Nominal size	Ø bore	d max	Catalogue No. with glass key
2	1.5	14.5	KSH 02006E 01
3	2.5	18.8	KSH 02006E 02
4	4	21.5	KSH 02006E 03

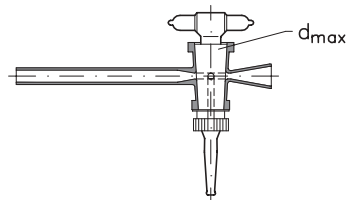

## CZAKO STOPCOCKS

Under this name, we supply these three way conical stopcocks with an 120° angle bore in the hollow glass key according to DIN 12 563. The different types are listed in the table below.

 The keys are made as hollow glass keys.

### Czako stopcocks with bending arms

Nominal size	Ø bore	d max	Catalogue No. with glass key
2	1.5	14.5	KSH 02008C 01
3	2.5	18.8	KSH 02008C 02
4	4	21.5	KSH 02008C 03

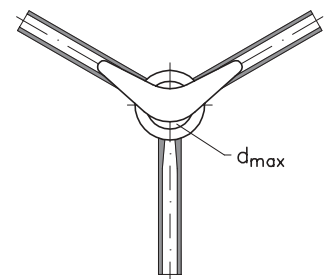

### Czako stopcocks with capillary arms

Nominal size	Ø bore	d max	Catalogue No. with glass key
2	1.5	14.5	KSH 02009 01
3	2.5	18.8	KSH 02009 02

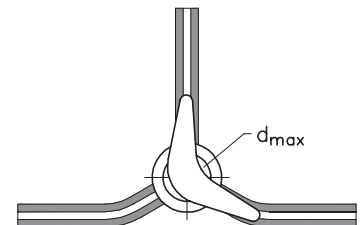

### Czako stopcocks with enlarged arm

Nominal size	Ø bore	d max	Catalogue No. with glass key
2	1.5	14.5	KSH 02008E 01
3	2.5	18.8	KSH 02008E 02
4	4	21.5	KSH 02008E 03

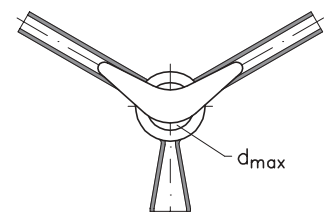

# STOPCOCKS/VALVES

## PUMP STOPCOCKS

The following conical stopcocks are suitable to lock the connection tubes between laboratory glass devices and vacuum pumps. Delivered with hollow glass keys according to DIN 12 545.

Examples for application, see catalogue part "Apparatus and Units".

### Right angle pump stopcocks

Nominal size	Ø bore	d max	Catalogue No. with glass key
2	2	14.5	KSH 02013 01
3	2.5	14.5	KSH 02013 02
4	4	18.8	KSH 02013 03
6	6	21.5	KSH 02013 04
8	8	24.0	KSH 02013 05
10	10	29.2	KSH 02013 06
15	15	45.0	KSH 02013 08

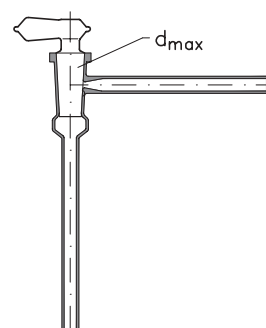

### Two-way pump stopcocks

Nominal size	Ø bore	d max	Catalogue No. with glass key
2	2	14.5	KSH 02014 01
3	2.5	14.5	KSH 02014 02
4	4	18.8	KSH 02014 03
6	6	21.5	KSH 02014 04
8	8	24.0	KSH 02014 05
10	10	29.2	KSH 02014 06
15	15	45.0	KSH 02014 08

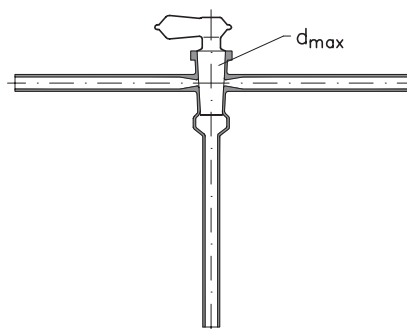

### Single way pump stopcocks

Nominal size	Ø bore	d max	Catalogue No. with glass key
2	2	14.5	KSH 02015 01
3	2.5	14.5	KSH 02015 02
4	4	18.8	KSH 02015 03
6	6	21.5	KSH 02015 04
8	8	24.0	KSH 02015 05
10	10	29.2	KSH 02015 06
15	15	45.0	KSH 02015 08

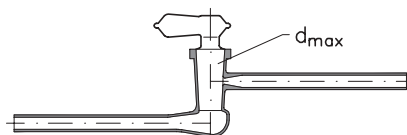

## HIGH VACUUM STOPCOCKS, SAFETY PATTERN

These stopcocks are a special design of the pump stopcocks described before. High vacuum stopcocks, safety pattern are used in vacuum apparatus and serve as locking device.

Due to the closed lower part (chamber), a higher tightness is reached compared with pump stopcocks.

### High vacuum stopcocks, safety pattern with oblique arms

Nominal size	Ø bore	d max	Catalogue No. with glass key
3	3	14.5	KSH 02016A 01
4	4	18.8	KSH 02016A 02
6	6	21.5	KSH 02016A 03
8	8	24.0	KSH 02016A 04
10	10	29.2	KSH 02016A 05

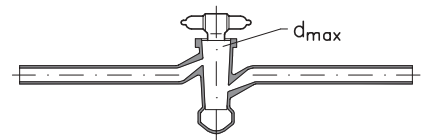

### High vacuum stopcocks, safety pattern with moulding in the key

Nominal size	Ø bore	d max	Catalogue No. with glass key
3	3	18.8	KSH 02016B 01
4	4	21.5	KSH 02016B 02
6	6	29.2	KSH 02016B 03
8	8	34.5	KSH 02016B 04
10	10	45.0	KSH 02016B 05

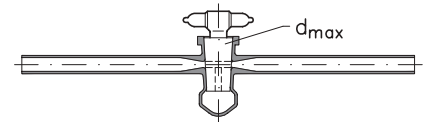

### High vacuum stopcocks, safety pattern with straight arms

Nominal size	Ø bore	d max	Catalogue No. with glass key
3	3	14.5	KSH 02016C 01
4	4	18.8	KSH 02016C 02
6	6	21.5	KSH 02016C 03
8	8	24.0	KSH 02016C 04
10	10	29.2	KSH 02016C 05

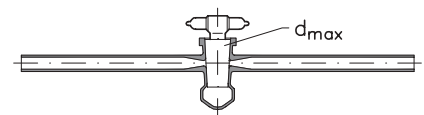

## VALVES WITH ARMS FOR MANIPULATORS

Besides stopcocks, valves are the most employed locking devices in laboratory technique. Because of their various use, they have to fulfil many jobs. These jobs reach from simple locking of a liquid at normal pressure to use at high vacuum.

This variety of applications has not only led to a wide range of designs, but also to spindle valves with higher or lower quality standard with the same cost/performance ratio. So the user has the possibility to choose lower price locking devices for simple purposes.

All designs and types have an utmost universal corrosion resistance, because the media can only get in touch with Borosilicate glass 3.3 (valve body) and PTFE (spindle).

Additional, all types are fitted with a key locking device, what prevents complete unscrewing of the spindle out of the valve body. The appropriate requirements for safety in laboratory are fully met.

## HIGH VACUUM - SPINDLE VALVES

All these products of highest quality standard distinguish by the very robust construction and minimal leakage rate. O-rings, fitted in the valve stamp and with adjustable pressing power, guarantee an excellent sealing between spindle and body. This and the metal cone in the spindle ensure a perfect guiding of the valve insert. Therefore, high vacuum spindle valves cover the whole range of requirements for use in laboratory, reaching from use at high vacuum to on/off functions for liquids at normal pressure. The only use of these valve can reduce the costs of storage.

The valve throttles in all designs are made of glass fibre reinforced Polyamide and is so sufficient corrosion resistant.

Special designs are available on request.



High vacuum spindle valves can be used up to a temperature of 230 °C. But we recommend the use of Rulon valve stamps for temperatures higher than 180 °C.

The glass body and the upper part of the valve for all designs without and with tempering jacket (which have a longer spindle) are interchangeable. They can be ordered as single components.

## Straight valves

Nominal size	d x s	Catalogue No. glass part	Catalogue No. upper part	Catalogue No. valve complete
3	8 x 1.5	LSG 12019GT	LSG 12019OT	LSG 12019V
6	10 x 1.5	LSG 12020GT	LSG 12020OT	LSG 12020V
10	15 x 1.8	LSG 12021GT	LSG 12021OT	LSG 12021V
15	22 x 2.5	LSG 12022GT	LSG 12022OT	LSG 12022V

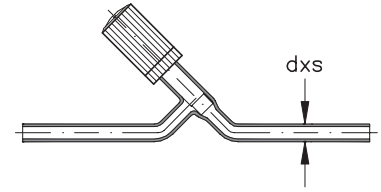

## Straight valve, reinforced

Nominal size	d x s	Catalogue No. glass part	Catalogue No. upper part	Catalogue No. valve complete
3	10 x 1.5	LSG 12019EGT	LSG 12019OT	LSG 12019EV
6	12 x 1.5	LSG 12020EGT	LSG 12020OT	LSG 12020EV
10	20 x 1.8	LSG 12021EGT	LSG 12021OT	LSG 12021EV
15	26 x 2.5	LSG 12022EGT	LSG 12022OT	LSG 12022EV

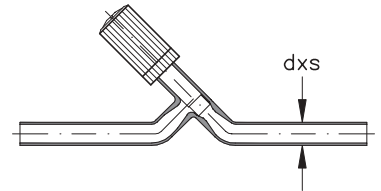

## Straight valves with tempering jacket

Nominal size	d x s	d1 x s1	Catalogue No. glass part	Catalogue No. upper part	Catalogue No. valve complete
3	8 x 1.5	24 x 1.8	LSG 12019GTT	LSG 12019OTT	LSG 12019VT
6	10 x 1.5	28 x 2	LSG 12020GTT	LSG 12020OTT	LSG 12020VT
10	15 x 1.8	34 x 2	LSG 12021GTT	LSG 12021OTT	LSG 12021VT
15	22 x 2.5	48 x 2.3	LSG 12022GTT	LSG 12022OTT	LSG 12022VT

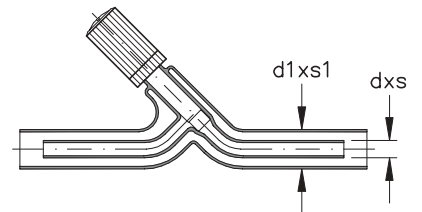

## Valves, right angle

Nominal size	d x s	Catalogue No. glass part	Catalogue No. upper part	Catalogue No. valve complete
3	8 x 1.5	LSG 12024GT	LSG 120190T	LSG 12024V
6	10 x 1.5	LSG 12025GT	LSG 120200T	LSG 12025V
10	15 x 1.8	LSG 12026GT	LSG 120210T	LSG 12026V
15	22 x 2.5	LSG 12027GT	LSG 120220T	LSG 12027V

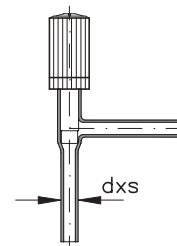

## Valves, right angle, reinforced

Nominal size	d x s	Catalogue No. glass part	Catalogue No. upper part	Catalogue No. valve complete
3	10 x 1.5	LSG 12024EGT	LSG 120190T	LSG 12024EV
6	12 x 1.5	LSG 12025EGT	LSG 120200T	LSG 12025EV
10	20 x 1.8	LSG 12026EGT	LSG 120210T	LSG 12026EV
15	26 x 2.5	LSG 12027EGT	LSG 120220T	LSG 12027EV

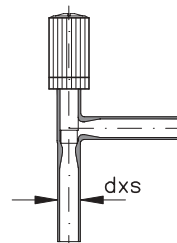

## Valves, right angle with tempering jacket

Nominal size	d x s	d1 x s1	Catalogue No. glass part	Catalogue No. upper part	Catalogue No. valve complete
3	8 x 1.5	24 x 1.8	LSG 12024GTT	LSG 120190TT	LSG 12024VT
6	10 x 1.5	28 x 2	LSG 12025GTT	LSG 120200TT	LSG 12025VT
10	15 x 1.8	34 x 2	LSG 12026GTT	LSG 120210TT	LSG 12026VT
15	22 x 2.5	48 x 2.3	LSG 12027GTT	LSG 120220TT	LSG 12027VT

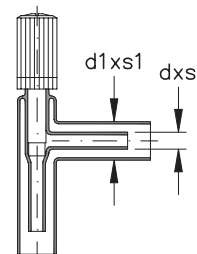

## Three-way valves

Nominal size	d x s	Catalogue No. glass part	Catalogue No. upper part	Catalogue No. valve complete
3	8 x 1.5	LSG 12039GT	LSG 12019OT	LSG 12039V
6	10 x 1.5	LSG 12040GT	LSG 12020OT	LSG 12040V
10	15 x 1.8	LSG 12041GT	LSG 12021OT	LSG 12041V
15	22 x 2.5	LSG 12042GT	LSG 12022OT	LSG 12042V

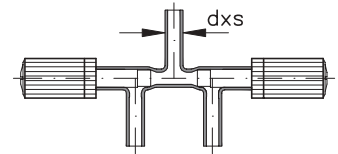

## Three-way valves, reinforced

Nominal size	d x s	Catalogue No. glass part	Catalogue No. upper part	Catalogue No. valve complete
3	10 x 1.5	LSG 12039EGT	LSG 12019OT	LSG 12039EV
6	12 x 1.5	LSG 12040EGT	LSG 12020OT	LSG 12040EV
10	20 x 1.8	LSG 12041EGT	LSG 12021OT	LSG 12041EV
15	26 x 2.5	LSG 12042EGT	LSG 12022OT	LSG 12042EV

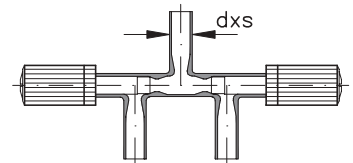

## HIGH PRESSURE VALVE

This valve is ideal for higher operation pressures. The glass part has been designed for pressures up to 10 bar.



Please see the important comments on page 4.10.

Nominal size	Catalogue No. glass part	Catalogue No. upper part	Catalogue No. valve complete
6	SAA 12050GT	SAA 12050OT	SAA 12050

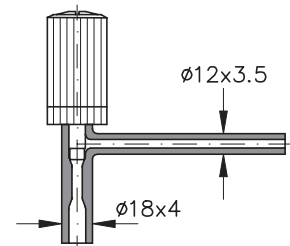

## BOTTOM DRAIN VALVES

These valves have an additional adjustable loaded spring in the upper part besides the work-holding device. The stamp is also pressed in its seat by the loaded spring, when the stamp is contracting during the cooling process. Therefore, a stable tightness is guaranteed in all operating circumstances.

 Please see also the important comments on page 4.10.

### Valves and upper parts

Nominal size	d x s	d1 x s1	Catalogue No. upper part	Catalogue No. valve complete
6	22 x 2.5	12 x 2.2	LSG 12044OT	LSG 12044
10	30 x 2.8	16 x 2.5	LSG 12045OT	LSG 12045
15	40 x 3.2	22 x 2.5	LSG 12046OT	LSG 12046

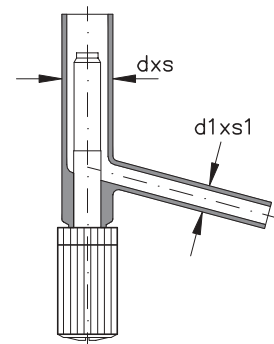

### Glass parts

Nominal size	d	h	Catalogue No. glass part
6	6.6	125	LSG 12044GT
10	12.6	130	LSG 12045GT
15	16.6	153	LSG 12046GT

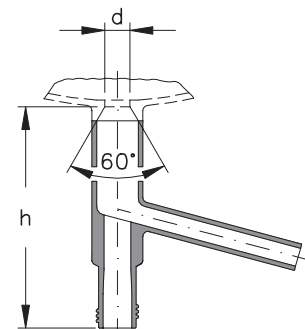

## ALL-ROUND SPINDLE VALVES

This simple and good value version of spindle valves without additional seal in the upper part is recognisable at the blue cap.

All-round valves are suitable for universal use in laboratory devices, when only low requirements for vacuum tightness are needed.



The maximum operation temperature of these valves is 180 °C. Rulon stamps are not available.

Glass body and upper part with spindle are interchangeable in all designs.

### Straight valves

Nominal size	d x s	Catalogue No. glass part	Catalogue No. upper part	Catalogue No. valve complete
3	8 x 1.5	HAA 60160 01	HAA 60166 01	HAA 60161 01
6	10 x 1.5	HAA 60160 02	HAA 60166 02	HAA 60161 02
10	13 x 1.5	HAA 60160 03	HAA 60166 03	HAA 60161 03

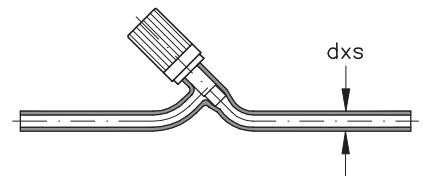

### Straight valves, with burette arm

Nominal size	d x s	d1 x s1	Catalogue No. glass part	Catalogue No. upper part	Catalogue No. valve complete
3	11 x 1.5	8 x 3	HAA 60162 01	HAA 60166 01	HAA 60163 01

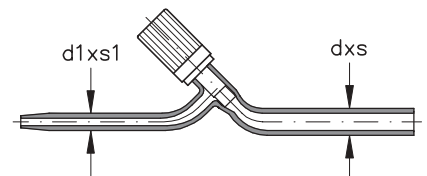

### Valves, right angle

Nominal size	d x s	Catalogue No. glass part	Catalogue No. upper part	Catalogue No. valve complete
3	8 x 1.5	HAA 60164 01	HAA 60166 01	HAA 60165 01
6	10 x 1.5	HAA 60164 02	HAA 60166 02	HAA 60165 02
10	13 x 1.5	HAA 60164 03	HAA 60166 03	HAA 60165 03

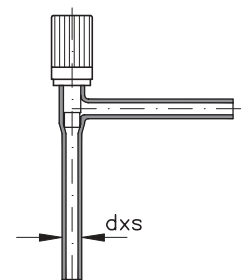

## GLASS NEEDLE VALVES

Due to the high shape stability of the glass needle, these valves provide an excellent flow control with an extremely high precision which cannot be reached with Elastomer-stamps.

The high precision guarantees the interchangeability of the glass body and the upper part of the valve. An additional sealing between these two components allows the use of that valve for laboratory devices operating under vacuum. The media can only get in touch with the material Borosilicate glass 3.3 granting an utmost universal corrosion resistance.

 The glass body and the upper part of the valve for all designs without and with tempering jacket (which have a longer spindle) are interchangeable.

### Straight valves

Nominal size	d x s	Catalogue No. glass part	Catalogue No. upper part	Catalogue No. valve complete
8	15 x 2.5	LSG 12010 01GT	LSG 12010 01OT	LSG 12010 01
12	22 x 2.5	LSG 12010 02GT	LSG 12010 02OT	LSG 12010 02

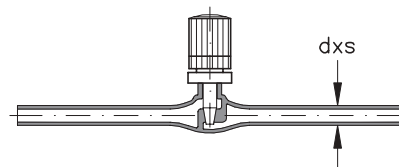

### Straight valves, with tempering jacket

Nominal size	d x s	d1 x s1	Catalogue No. glass part	Catalogue No. upper part	Catalogue No. valve complete
8	15 x 2.5	42 x 2.3	LSG 12010 01GTT	LSG 12010 01OTT	LSG 12010 01T
12	22 x 2.5	48 x 2.3	LSG 12010 02GTT	LSG 12010 02OTT	LSG 12010 02T

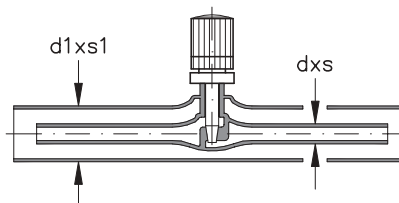

## Valves, right angle

Nominal size	d x s	Catalogue No. glass part	Catalogue No. upper part	Catalogue No. valve complete
8	15 x 2.5	LSG 12011 01GT	LSG 12010 01OT	LSG 12011 01
12	22 x 2.5	LSG 12011 02GT	LSG 12010 02OT	LSG 12011 02

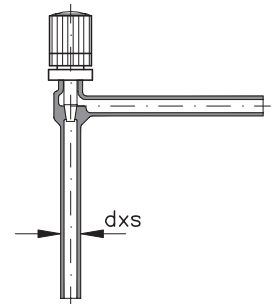

## Valves, right angle with tempering jacket

Nominal size	d x s	d1 x s1	Catalogue No. glass part	Catalogue No. upper part	Catalogue No. valve complete
8	15 x 2.5	42 x 2.3	LSG 12011 01GTT	LSG 12010 01OTT	LSG 12011 01T
12	22 x 2.5	48 x 2.3	LSG 12011 02GTT	LSG 12010 02OTT	LSG 12011 02T

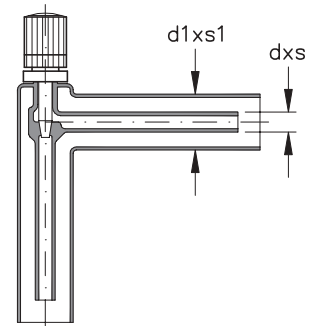

## Three-way valves

Nominal size	d x s	Catalogue No. glass part	Catalogue No. upper part	Catalogue No. valve complete
8	15 x 2.5	LSG 12016 01GT	LSG 12010 01OT	LSG 12016 01

